



**WILLIAM JOHNSTON
& COMPANY LIMITED**

Inverness Tel: +44 (0) 1463 238 673

autoclave@williamjohnston.co.uk

www.williamjohnston.co.uk

Autoclave

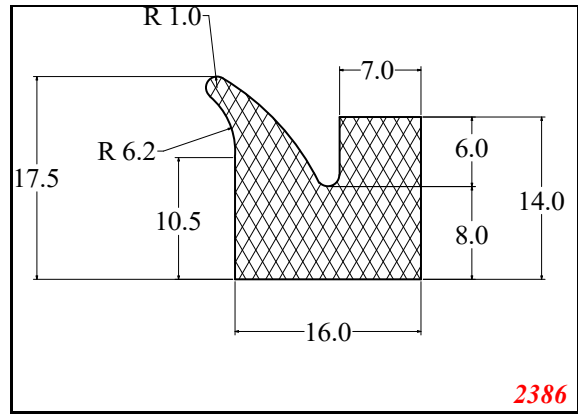
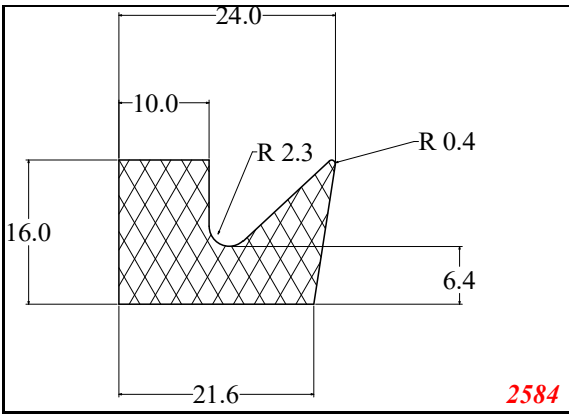
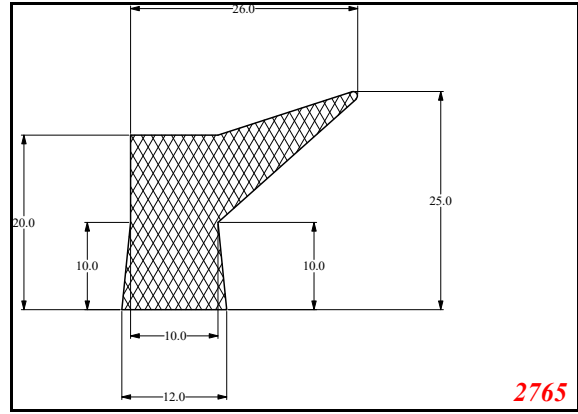
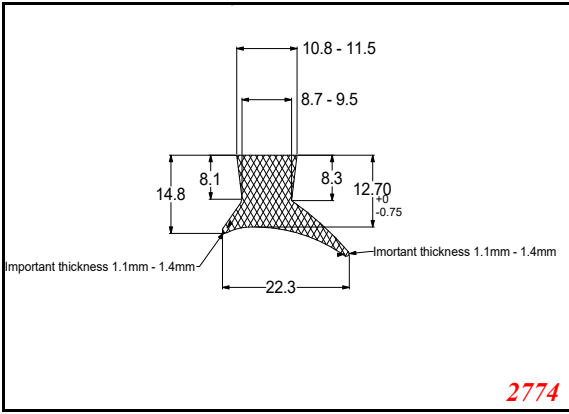
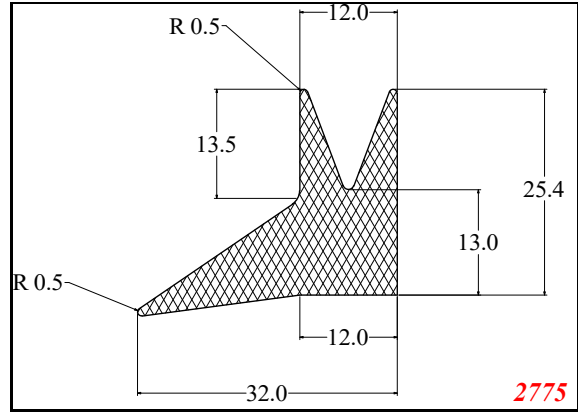
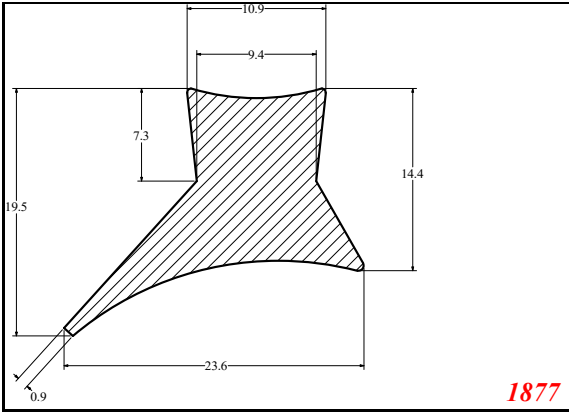

Autoclave

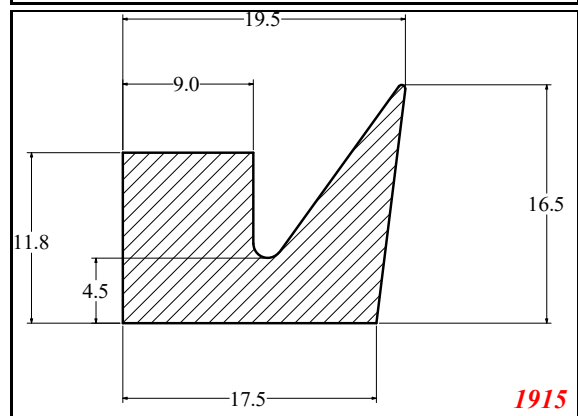
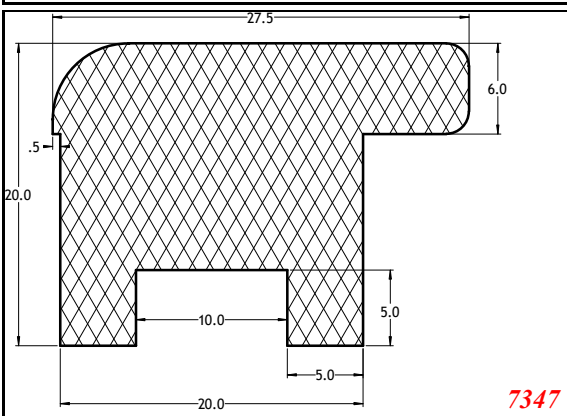
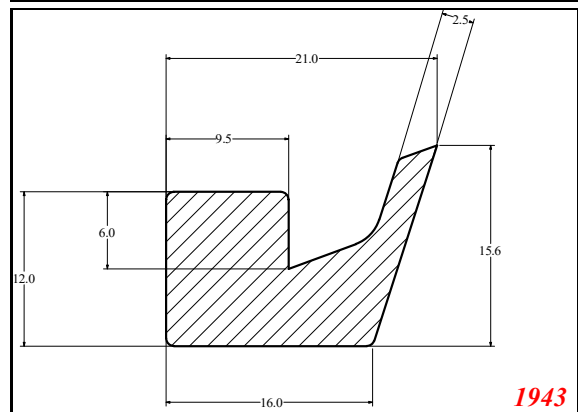
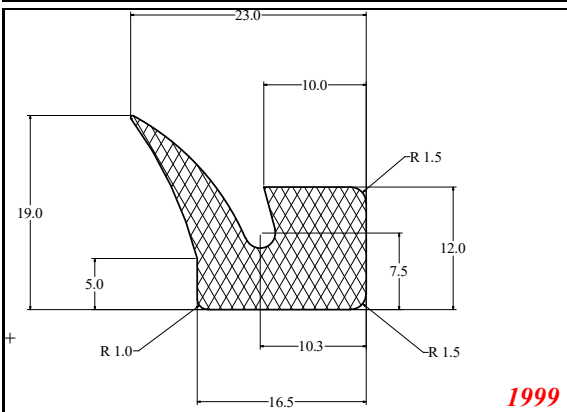
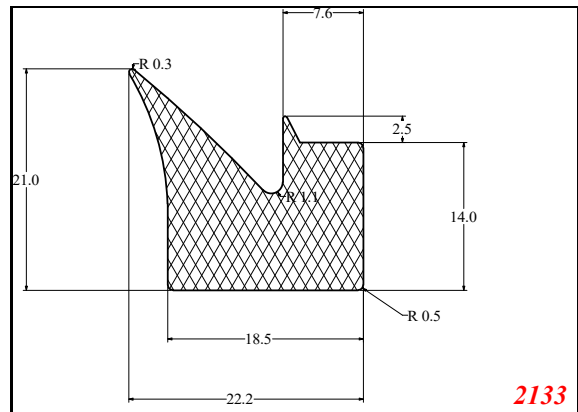
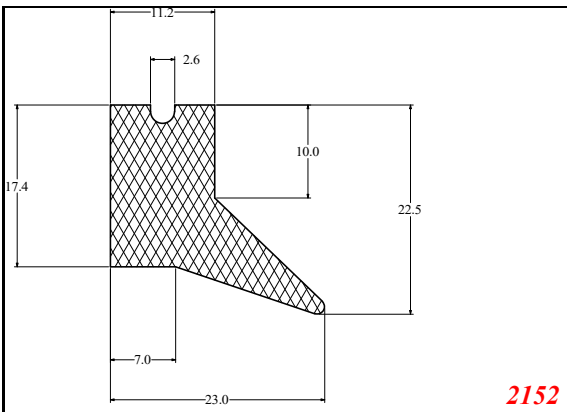
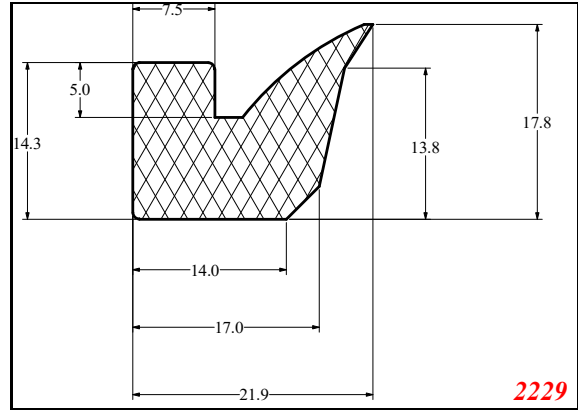
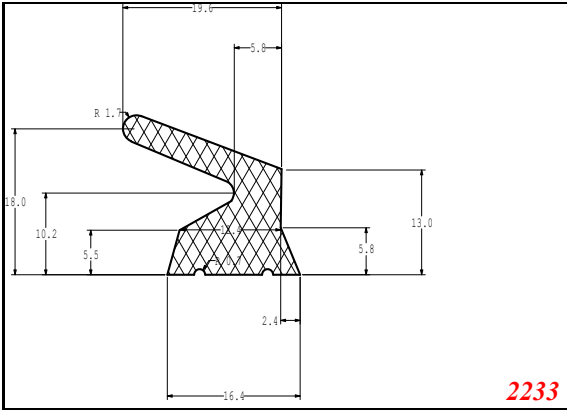

Autoclave

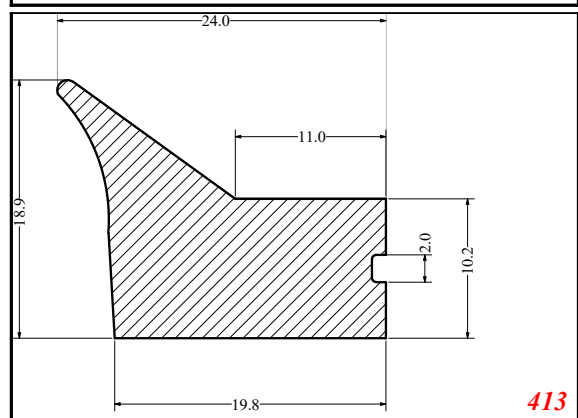
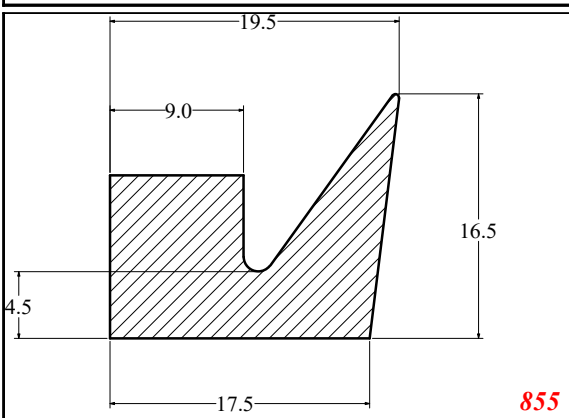
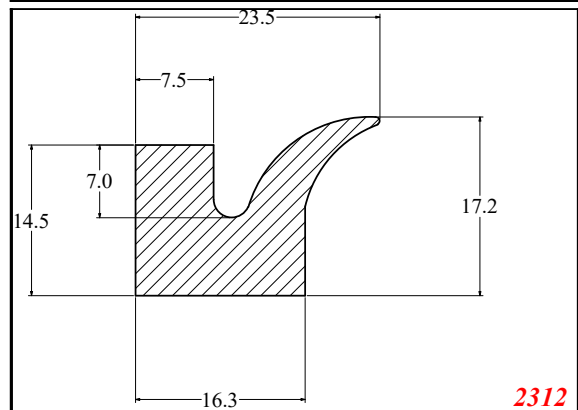
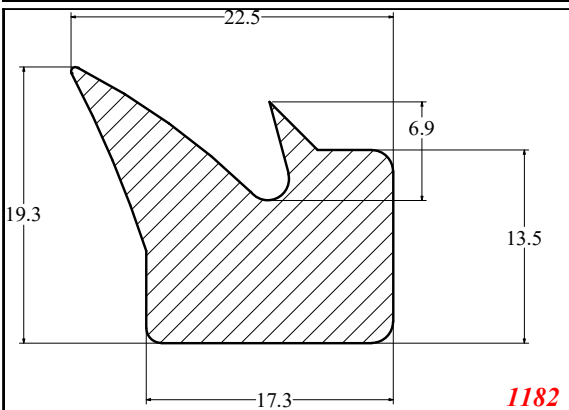
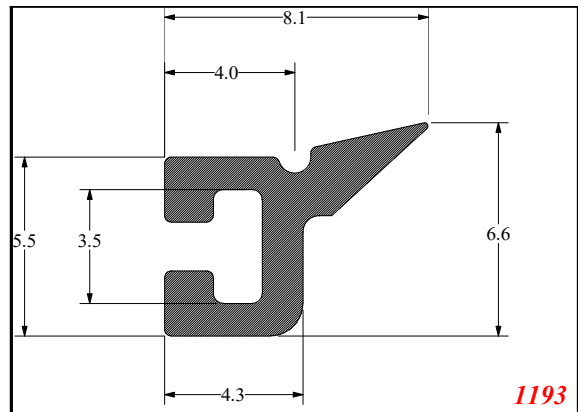
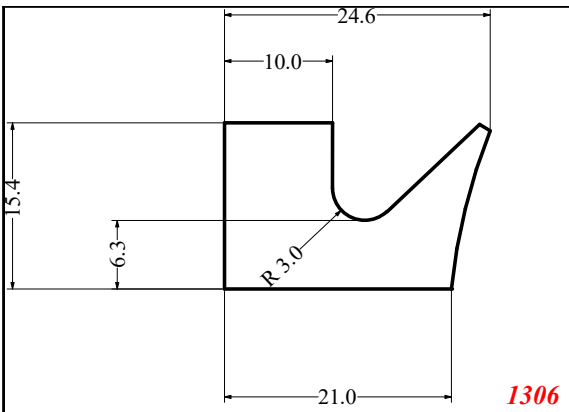
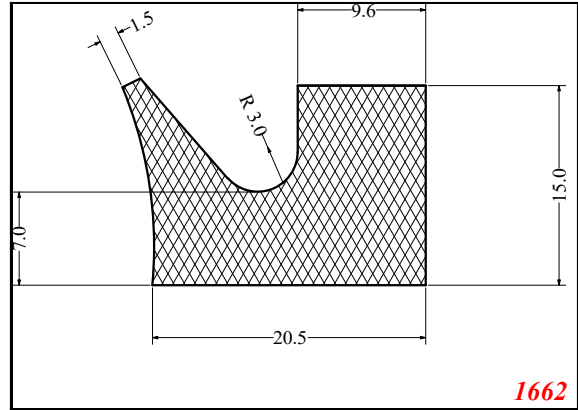
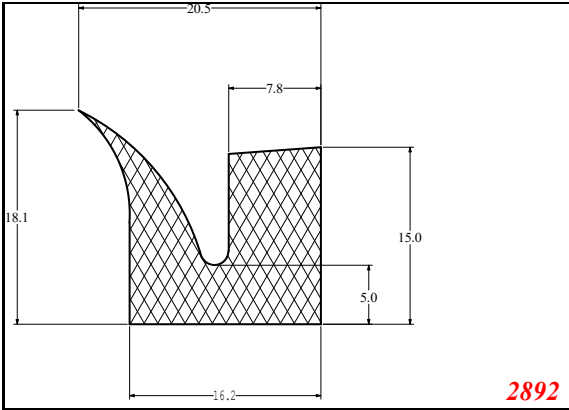

Autoclave

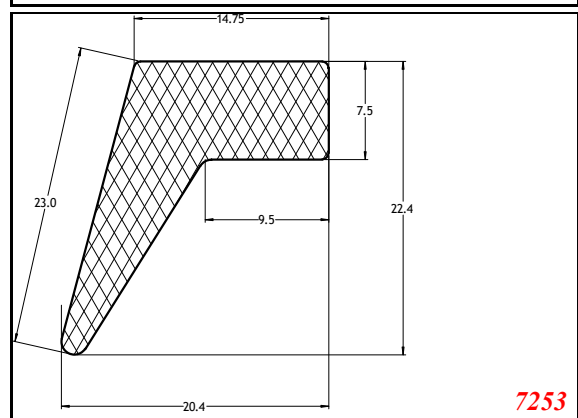
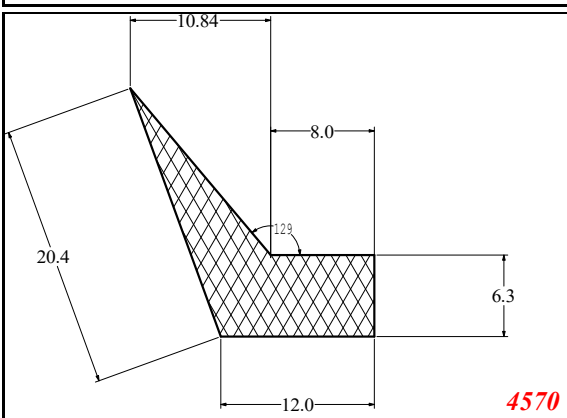
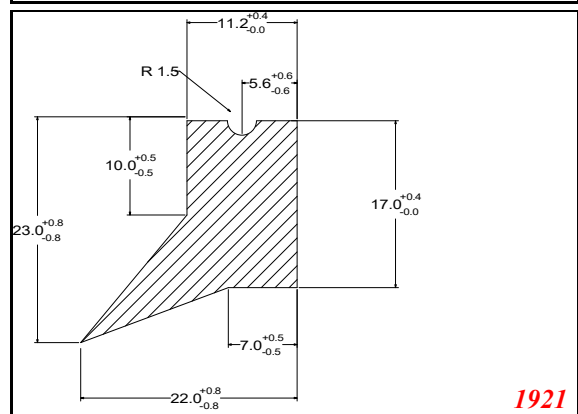
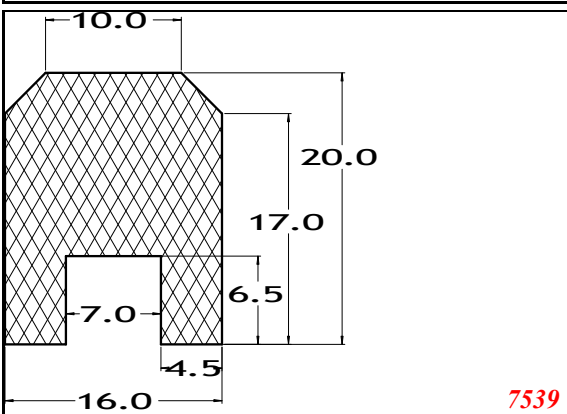
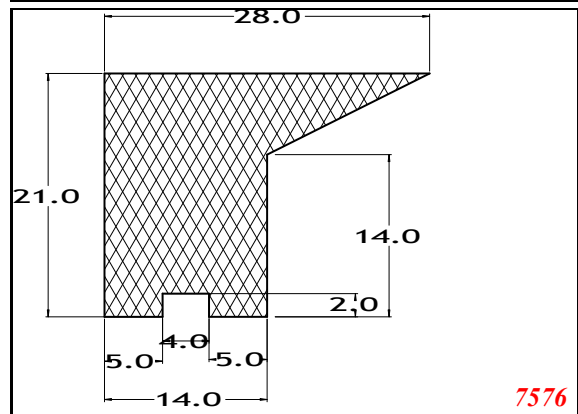
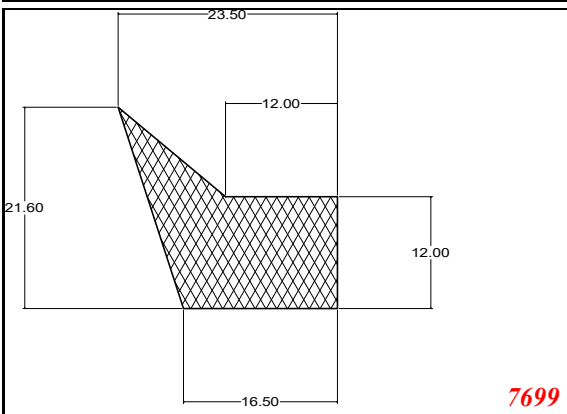
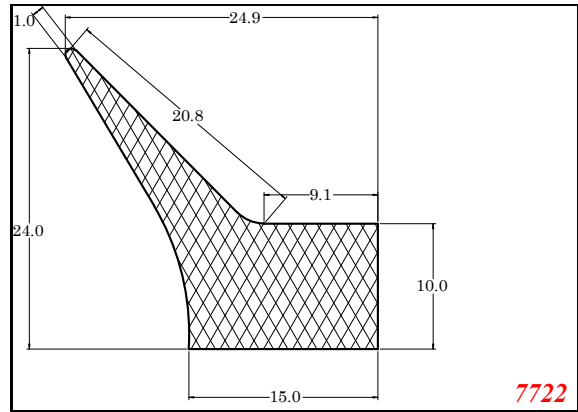
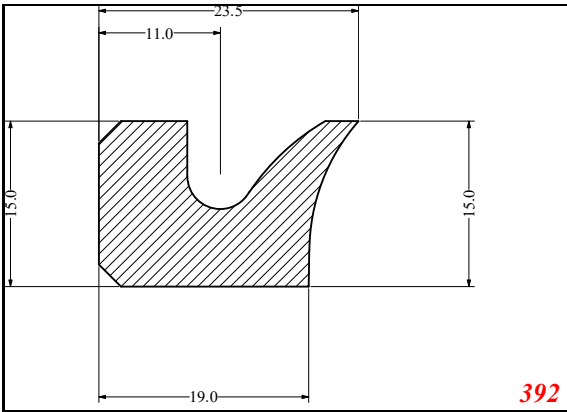

Autoclave

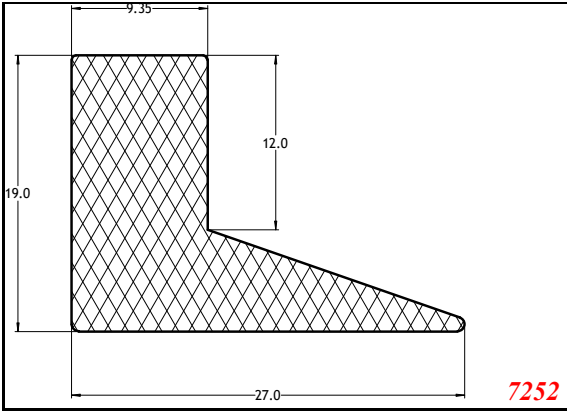

7252

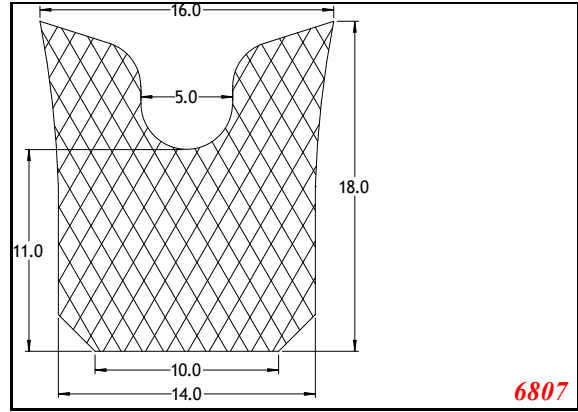

6807

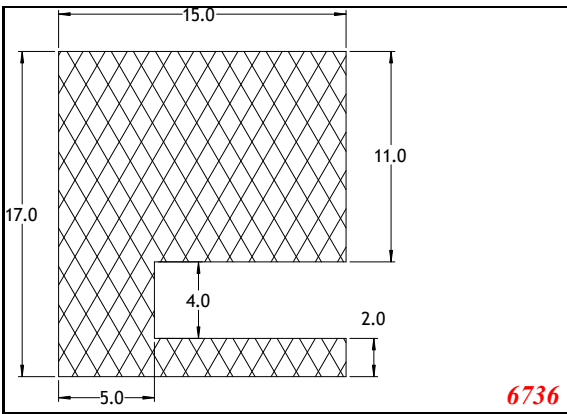

6736

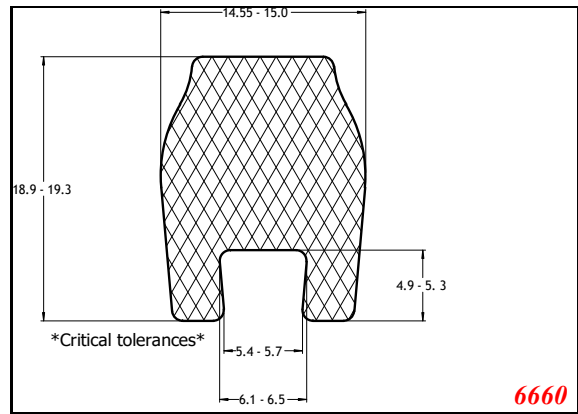

6660

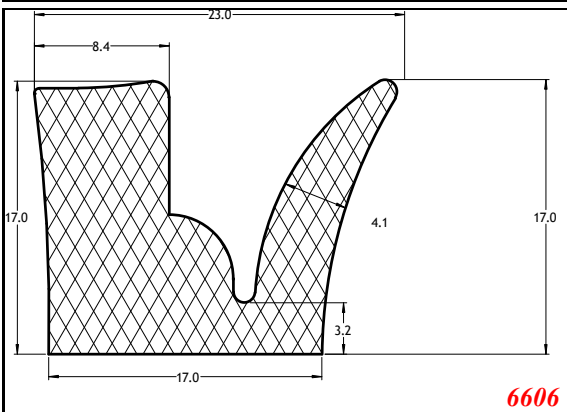

6606

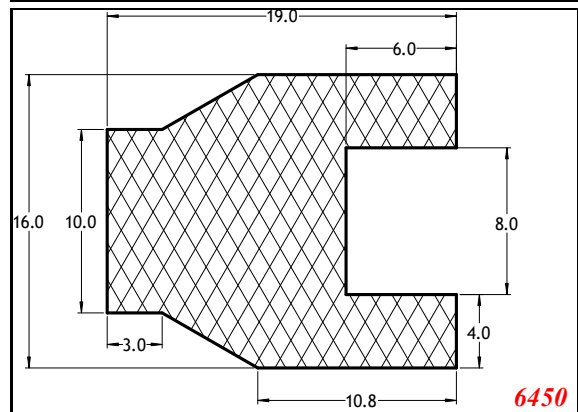

6450

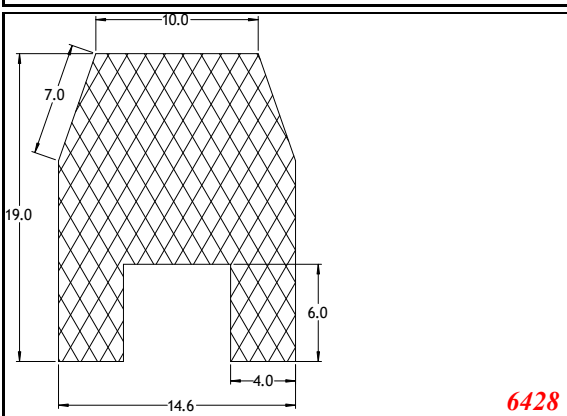

6428

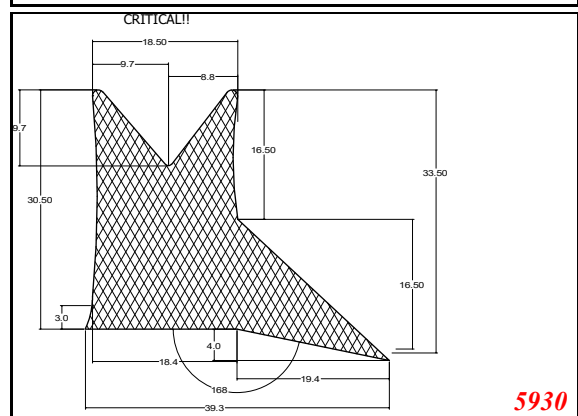

5930

Autoclave

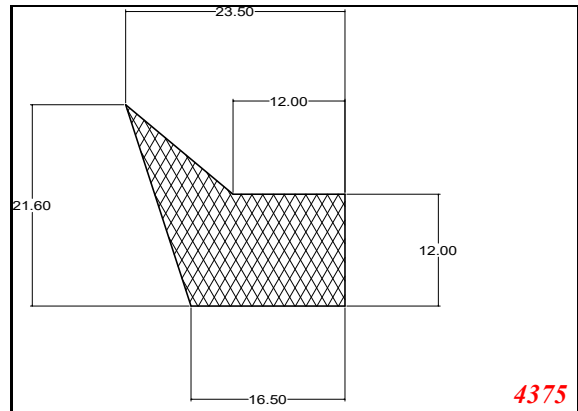
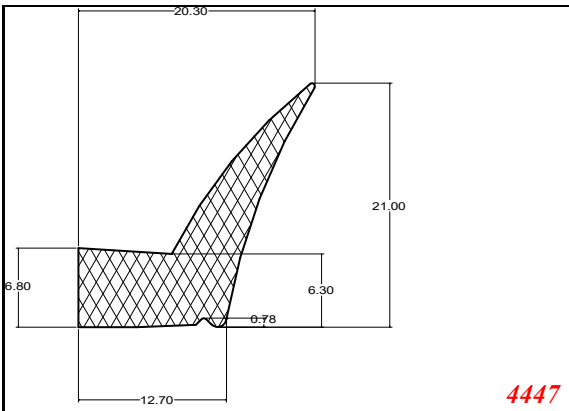
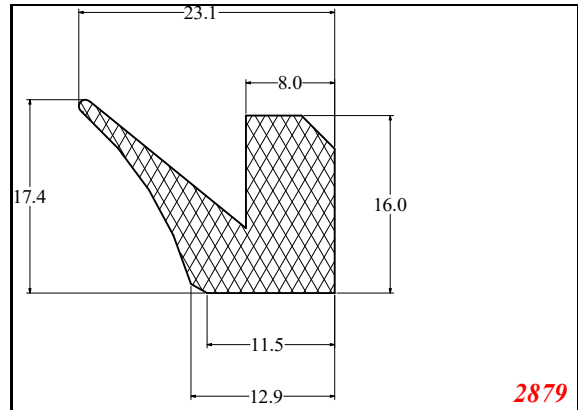
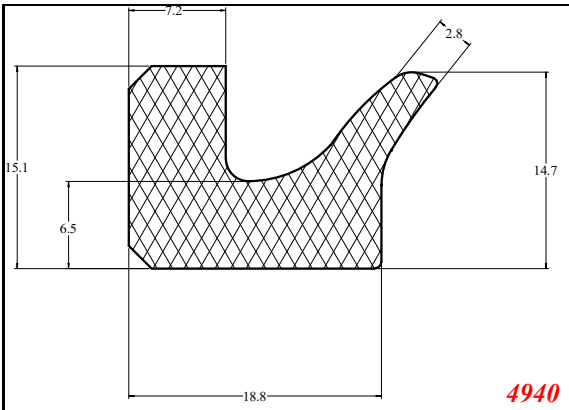
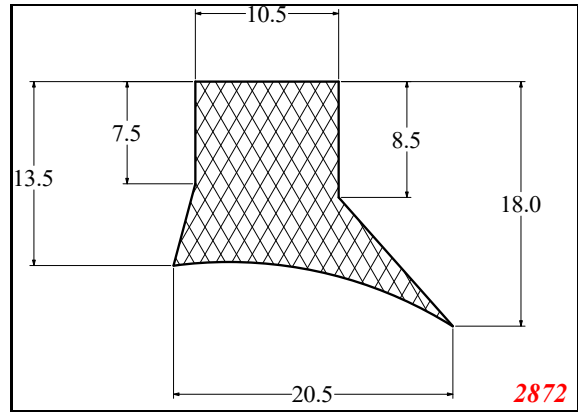
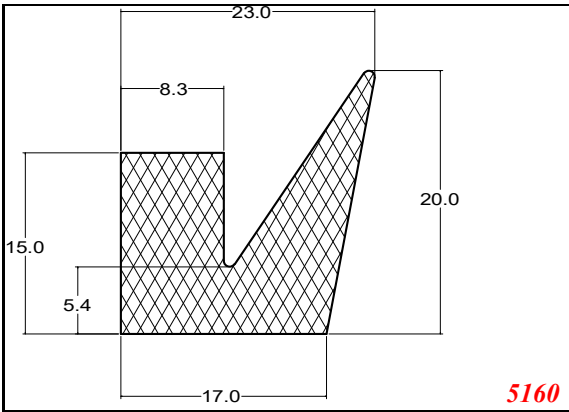
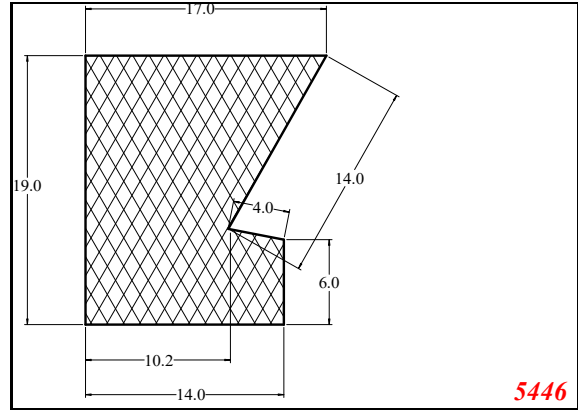
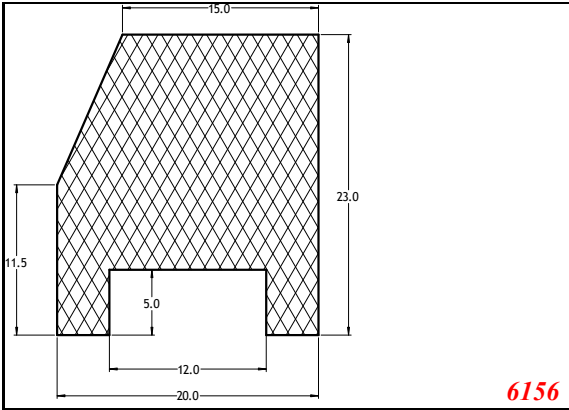

Autoclave

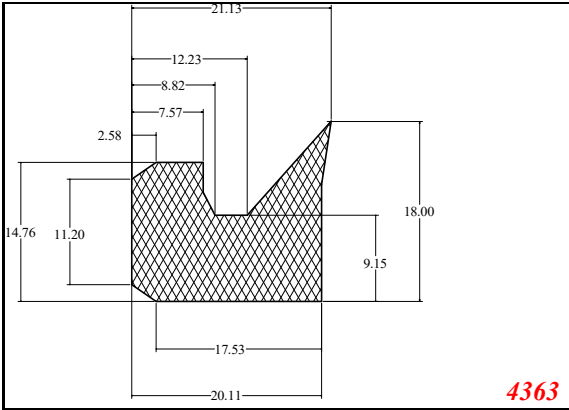

4363

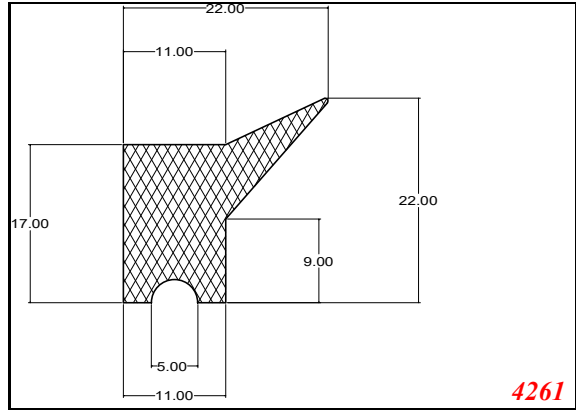

4261

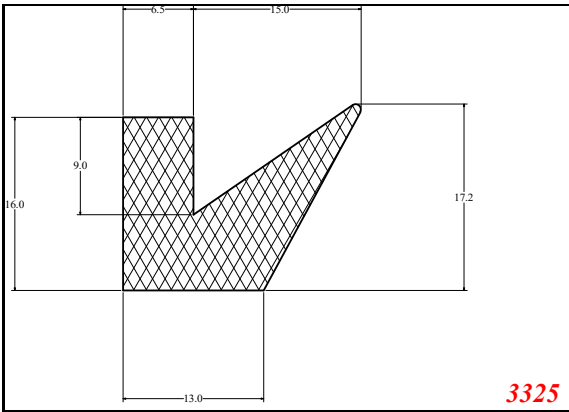

3325

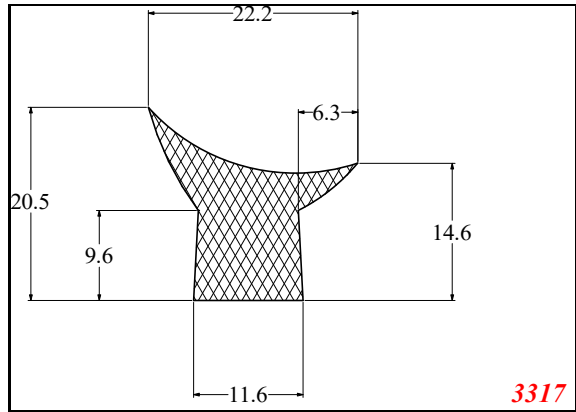

3317

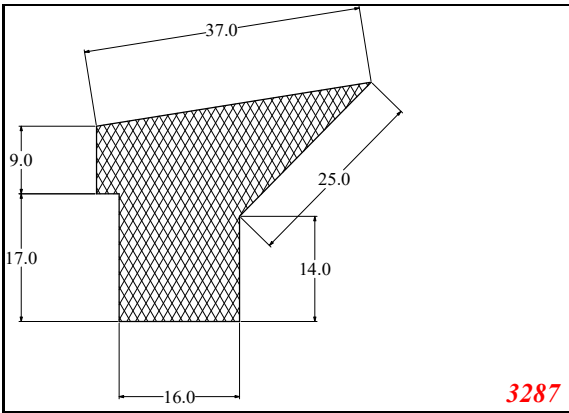

3287

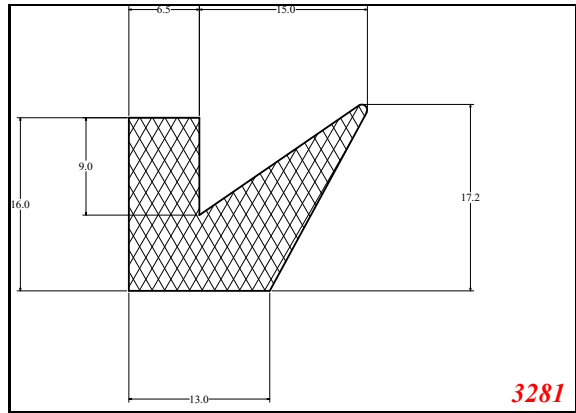

3281

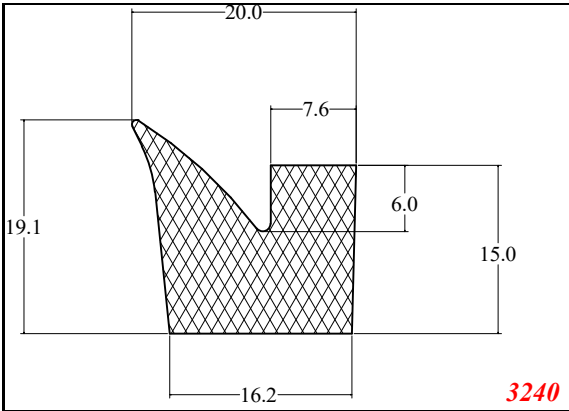

3240

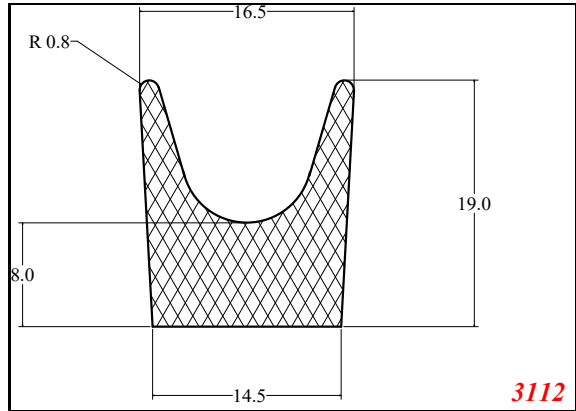

3112

Autoclave

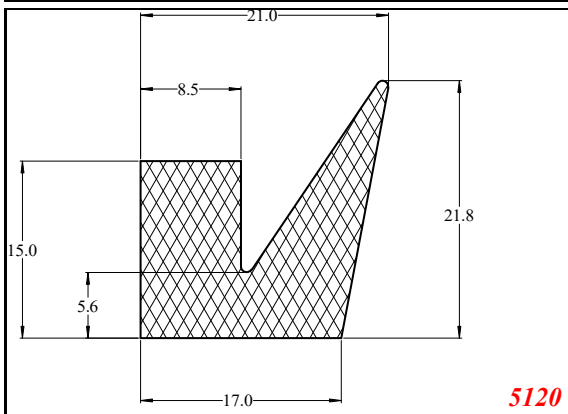
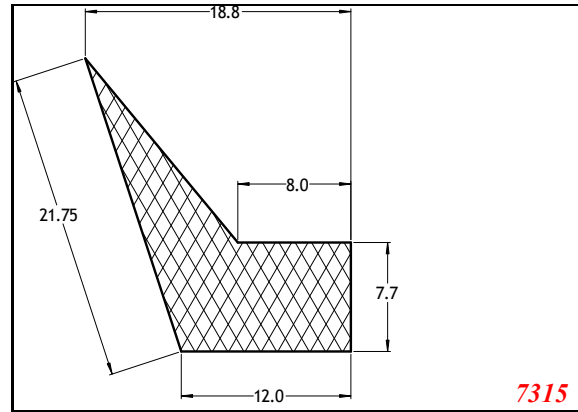
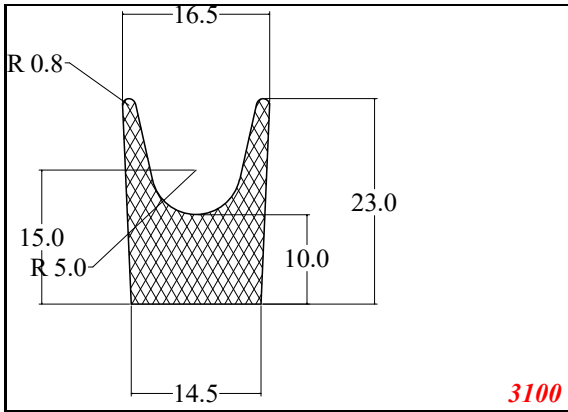

Failure to select the correct materials or products can result in damage to plant and equipment and personal injury. In specific applications, particularly where critical conditions exist, we suggest you contact us and we will consider with you the most suitable material or product. However, information supplied by William Johnston & Company Limited is intended only as technical co-operation and as a guide to the various uses of different products. No warranty is given in respect of information or recommendations by William Johnston & Company Limited which are only given for guidance and without any guarantee. The customer must satisfy themselves on the suitability of the material or product for the intended purpose. The correct fitting of products is the responsibility of the customer